

- 1** Attach mounting plate to cove, wall, shelf or cabinetry with mounting screws (not supplied).
- 2** Connect circuit board rail to mounting plate. Next attach lens to circuit board rail.
- 3** Fasten end-caps into C-shaped screw channels in both sides of circuit board rail. Tighten screws with Allen Key.
- 4** Connect fixture wires to low voltage wiring 24V DC constant voltage drivers with 120-277V input, TLDDL100W4100).

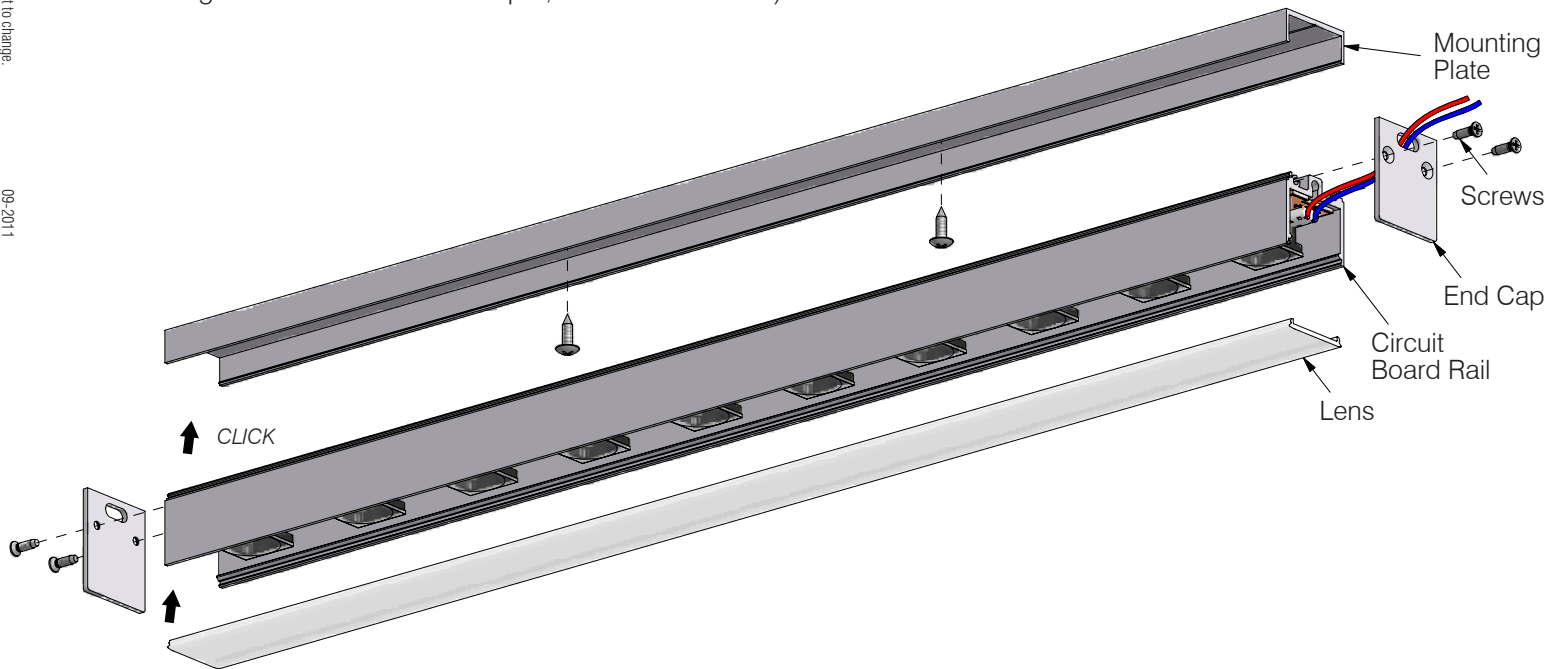

⚠ CAUTION

- Read all instructions.
- **WARNING: RISK OF FIRE OR ELECTRICAL SHOCK:** Do not make or alter any openings in the compartment of wiring or electrical components during installation. Do not alter or add ballasts, or any other electrical components.
- Installation and use of this fixture mounting assembly requires a person familiar with the construction and operation of luminaire electrical systems and the hazards involved, if not qualified, do not attempt installation.
- Turn off power before installation.
- Connect to appropriate 24V dc constant current driver only.
- Do not over tighten screws.
- Do not spray water on fixture during cleaning. Avoid using detergents with hand softeners, anti-bacterial agents, glass cleaners or acrylic cleaning products.
- **KEEP THESE INSTALLATION INSTRUCTIONS.**

Parts

- | | |
|----------------------------|---|
| • LED rail | 1 |
| • Cross countersunk screws | 4 |
| • End-caps | 2 |

Qty.

Tools

- Phillips screwdriver *not included*

Maintenance

- Clean with a soft cloth.

L106
Installation
Instructions