

L423

Recessed Downlight

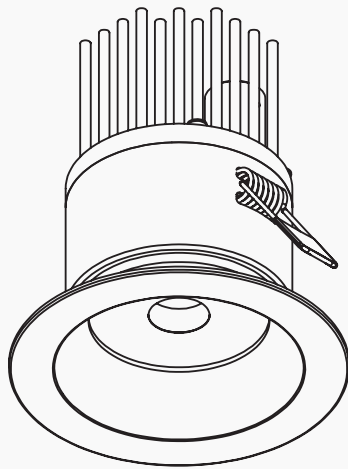

L423

Recessed Downlight

Parts

- LED Unit
- Non-Insulated Frame
- Driver Housing with Driver
- BX Connector and Conduit (Not Included)

Non-Insulated Frame Installation with Adjustable Bar Hanger 16"-22" (406-559 mm).

- 1) Mount frame by aligning bar hanger end so it is flush with bottom of joist. Hammer in built-in nailer.
- 2) While power is off, open driver housing by removing cover. Next remove appropriate knock out plug and thread supplied BX connector onto stripped BX cable. If using 'LUMEX' type cable, substitute clamp type BX connector. (*Connectors not included*)

**Connecting LEDs to a live driver will cause LEDs to Fail.*

- 3) Connect neutral (*white*) and line (*black*) leads, then replace driver housing cover.

**Wiring can be done subsequent to the drywall installation (See Retrofit Installation).*

- 4) After drywall installation cut $\text{Ø}2\ 3/4"$ ($\text{Ø}70\text{mm}$) hole using a gyproc saw or drywall trimmer.
- 5) Press springs inward while pushing fixture up through hole in drywall. Allow springs to release once on the other side. Trim should now rest against drywall covering the hole opening.

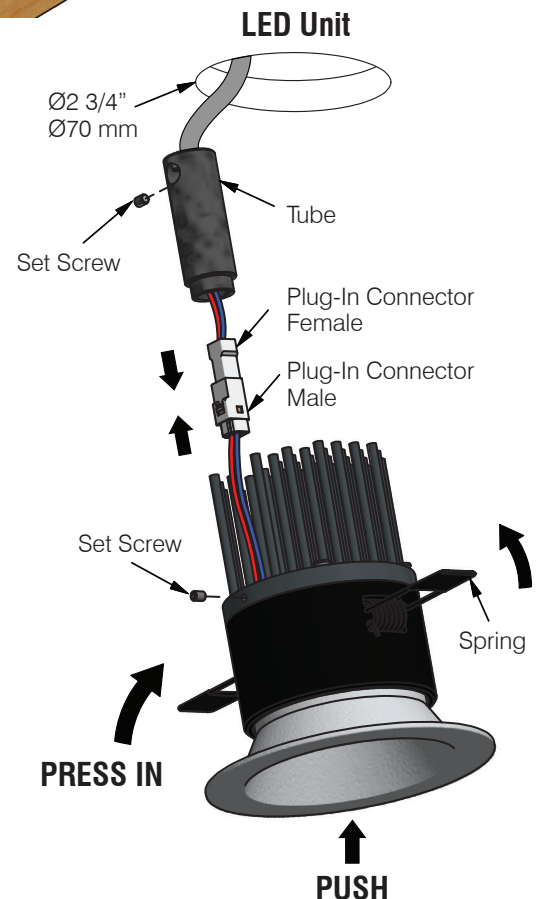
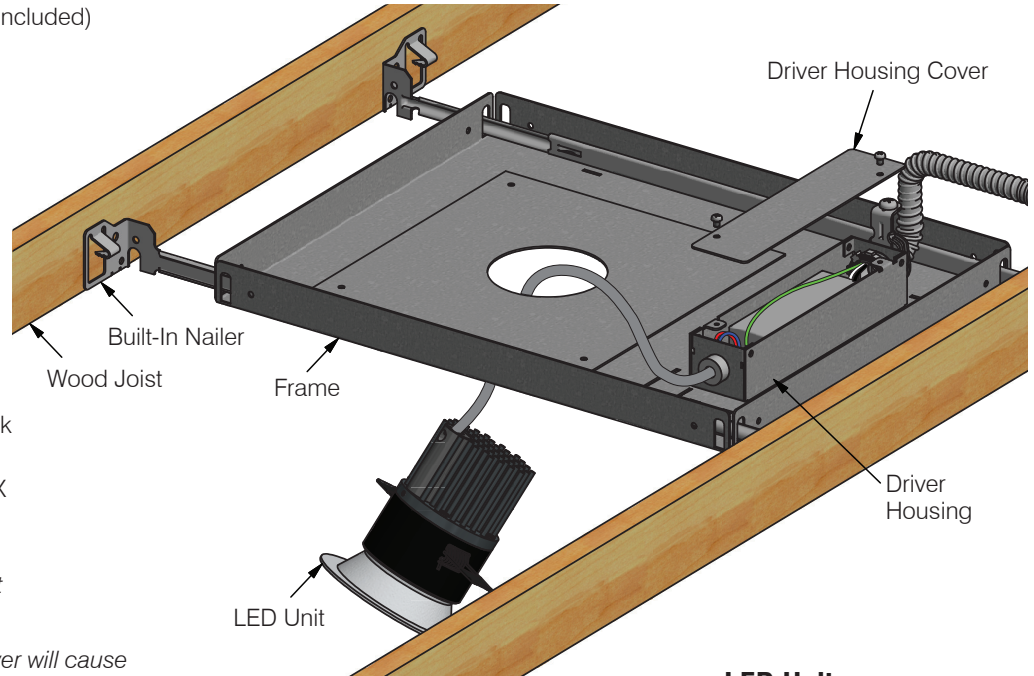
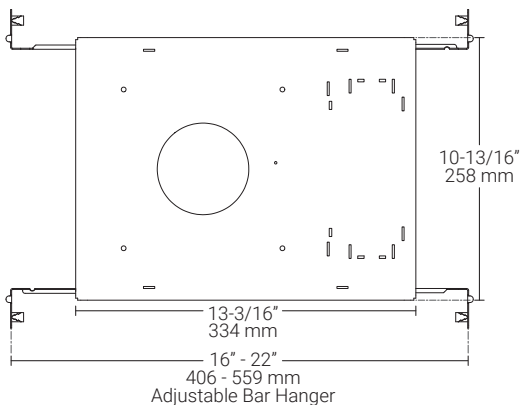

**Do not use lamp holder / LED trim unit as temporary lighting. Wire connection cannot support weight of hanging LED Unit.*

L423

Recessed Downlight

Parts

LED Unit
 Driver Housing with Driver
 BX Connector and Conduit (Not Included)

Retrofit Installation

- 1) While power is off, open driver housing by removing cover. Next remove appropriate knock out plug and thread supplied BX connector onto stripped BX cable.

If using 'LUMEX' type cable, substitute clamp type BX connector. (Connectors not included)

**Connecting LEDs to a live driver will cause LEDs to Fail.*

- 2) Connect neutral (white) and line (black) leads, then replace driver housing cover.
- 3) Insert driver housing through the $\text{Ø}2\frac{3}{4}$ " ($\text{Ø}70\text{mm}$) hole in the drywall.
- 4) Press springs inward while pushing fixture up through hole in drywall. Allow springs to release once on the other side.

Trim should now rest against drywall covering the hole opening.

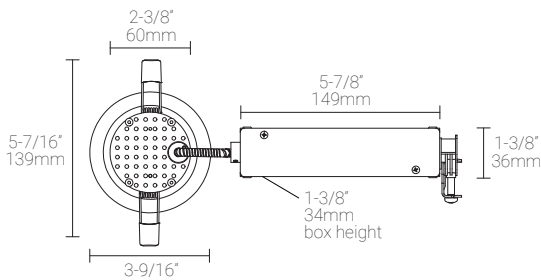
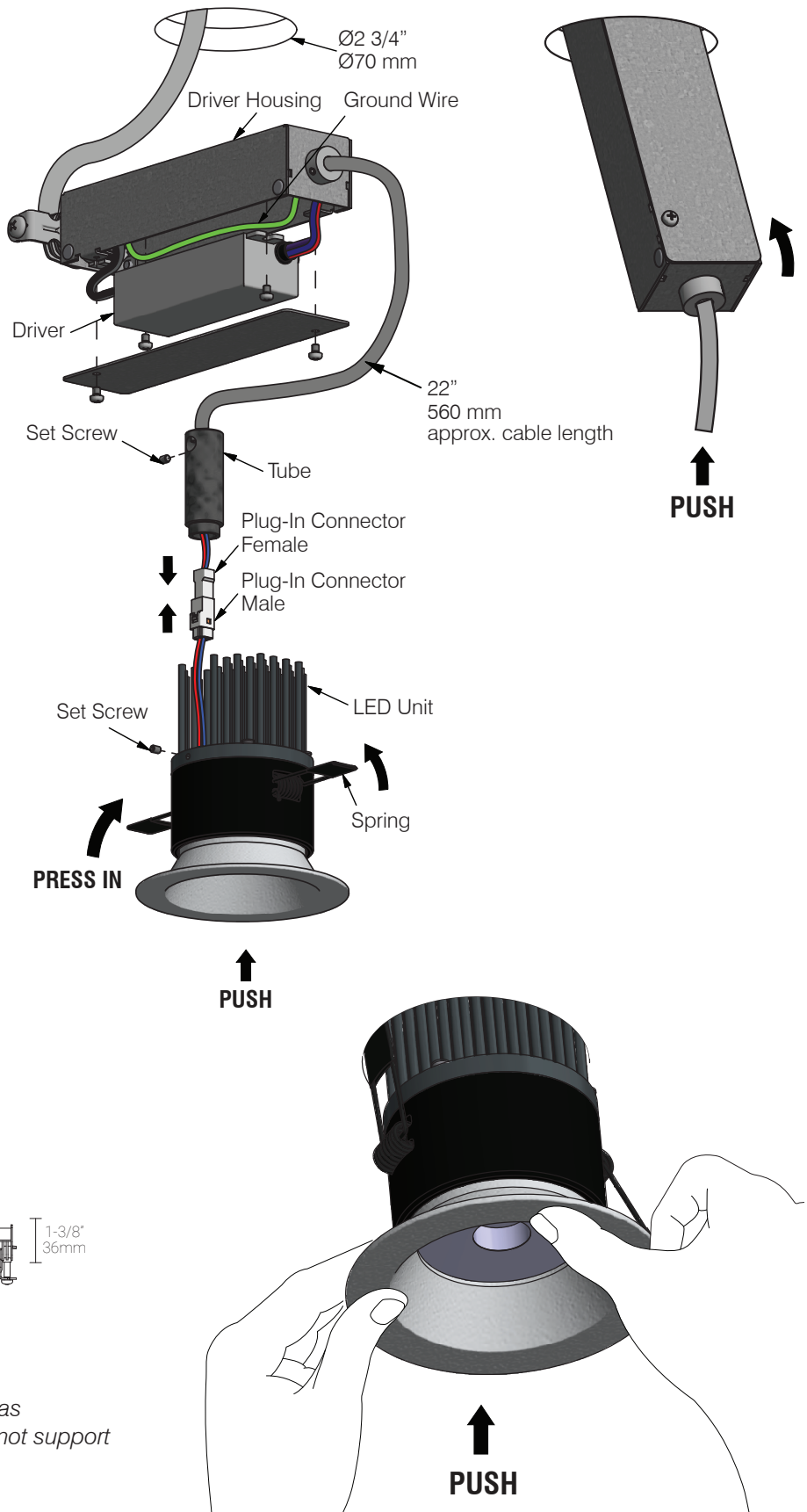

**Do not use lamp holder / LED trim unit as temporary lighting. Wire connection cannot support weight of hanging LED Unit.*

IMPORTANT SAFETY INSTRUCTIONS

KEEP THESE INSTALLATION INSTRUCTIONS

(Including General and Additional Markings for Fixtures)

(FOR MP LIGHTING LED LUMINAIRES, CLASS 3402-xx)

General and additional markings

1. For Use Only with Certified/NRTL Driver, Model _____
2. DRY LOCATIONS ONLY

Installation instructions

1. The grounding installation shall be done in accordance with CEC-Part 1.
2. WARNING: RISK OF FIRE OR ELECTRIC SHOCK: DO NOT MAKE OR ALTER ANY OPENINGS IN THE COMPARTMENT OF WIRING OR ELECTRICAL COMPONENTS DURING INSTALLATION. DO NOT ALTER OR ADD BALLASTS, OR ANY OTHER ELECTRICAL COMPONENTS.
3. INSTALLATION AND USE OF THIS FIXTURE MOUNTING ASSEMBLY REQUIRES A PERSON FAMILIAR WITH THE CONSTRUCTION AND OPERATION OF LUMINAIRE ELECTRICAL SYSTEMS AND THE HAZARD INVOLVED, IF NOT QUALIFIED, DO NOT ATTEMPT INSTALLATION. CONTACT A QUALIFIED ELECTRICIAN.
4. TURN OFF POWER BEFORE INSTALLATION.
5. KEEP THESE INSTALLATION INSTRUCTIONS.

CONSIGNES DE SÉCURITÉ IMPORTANTES

CONSERVER CES INSTRUCTIONS D'INSTALLATION

(Dont le général et marques supplémentaires pour les appareils)

(Pour les luminaires LED MP D'ÉCLAIRAGE , CLASS 3402 -xx)

Général et marquages supplémentaires

1. A utiliser uniquement avec Certified / NRTL pilote, modèle _____
2. POUR EMPLACEMENTS SECS SEULEMENT

Les instructions d'installation

1. L'installation de mise à la terre doit être fait en conformité avec CEC Partie 1.
2. AVERTISSEMENT : RISQUE D'INCENDIE OU D'ÉLECTROCUTION : NE PAS FAIRE OU MODIFIER DES OUVERTURES DANS LE COMPARTIMENT DE CÂBLAGE OU DE COMPOSANTS ÉLECTRIQUES LORS DE L'INSTALLATION. NE PAS MODIFIER OU AJOUTER DES BALLASTS, OU AUTRES COMPOSANTS ÉLECTRIQUES
3. CE PRODUIT DOIT ÊTRE INSTALLÉ SELON LE CODE D'INSTALLATION PERTINENT, PAR UNE PERSONNE QUI CONNAÎT BIEN LE PRODUIT ET SON FONCTIONNEMENT AINSI QUE LES RISQUES INHÉRENTS. CONSULTER UN ÉLECTRICIEN QUALIFIÉ.
4. COUPER LE COURANT AVANT L'INSTALLATION.
5. CONSERVEZ CES INSTRUCTIONS.