

L508-L52

Installation Instructions

- 1** Drill a $\text{\O}1\text{-}1/2"$ (38mm) hole.
- 2** Connect fixture wires to low voltage wiring (remote LED driver 350mA or 700mA constant current).
- 3** To mount with spring, push L508 fixture with friction fit spring clip into $\text{\O}1\text{-}1/2"$ (38mm) hole until the cover is flat with the surface.

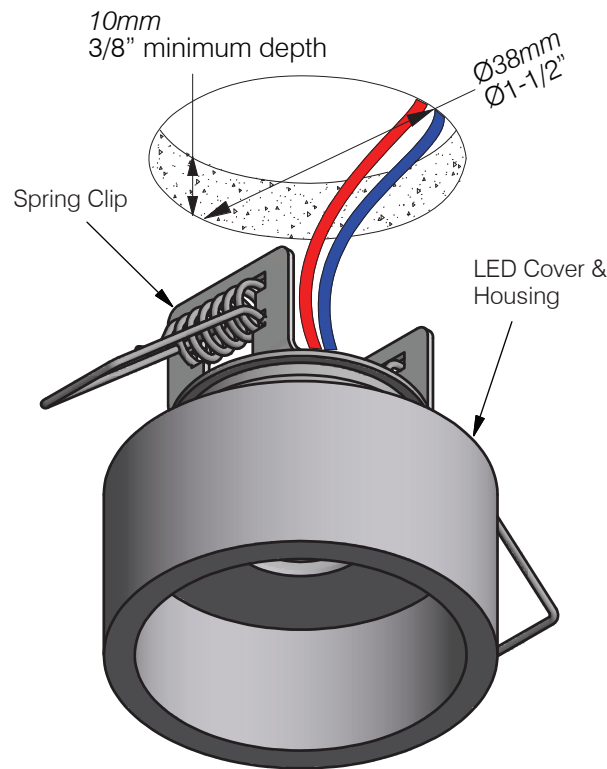

CAUTION

- Read all instructions.
- **WARNING: RISK OF FIRE OR ELECTRICAL SHOCK:** Do not make or alter any openings in the compartment of wiring or electrical components during installation. Do not alter or add ballasts, or any other electrical components.
- Installation and use of this fixture mounting assembly requires a person familiar with the construction and operation of luminaire electrical systems and the hazards involved, if not qualified, do not attempt installation.
- Turn off power before installation.
- Constant current driver only 350mA or 700mA.
- Do not spray water on fixture during cleaning. Avoid using detergents with hand softeners, anti-bacterial agents, glass cleaners or acrylic cleaning products.
- **KEEP THESE INSTALLATION INSTRUCTIONS.**

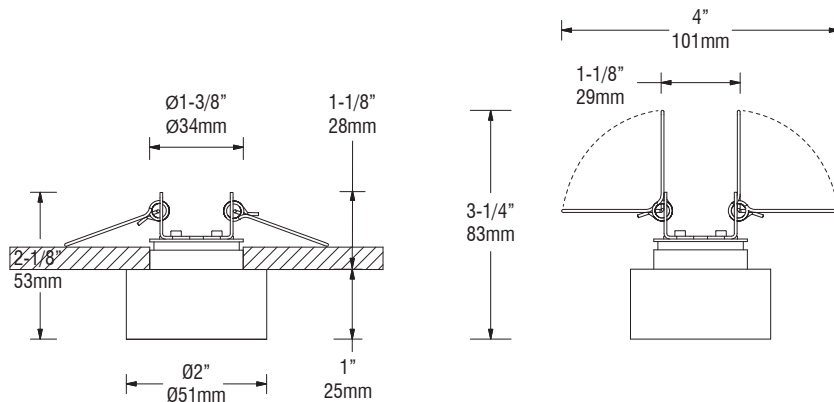

Parts	Qty.
• LED unit w/ spring clip	1

Maintenance

Clean using a soft cloth.



t1.877.708.1184 f604.708.1185 www.mplighting.com
16 West 4th Avenue, Vancouver BC V5Y 1G3, Canada

L508-L52

LED In-grade 1W / 2.5W

Parts

- L508 Flange
- LED unit w/ spring clip
- Wire connector x 2

- 1) Mount flange to electrical box so flange is flush with the face of drywall or setback 1/8" (3mm) max. from the face of drywall.
- 2) Connect fixture wires to low voltage wiring (remote LED driver constant current). The power to the driver must be off while wiring LED fixtures to drivers. **Connecting LEDs to a live driver will cause LEDs to Fail.*
- 3) Cut Ø1-1/2" (Ø38mm) hole in drywall to fit fixture.
- 4) To mount with spring, push L508 fixture with friction fit spring clip into Ø1-1/2" (38mm) hole until the cover is flat with the surface.

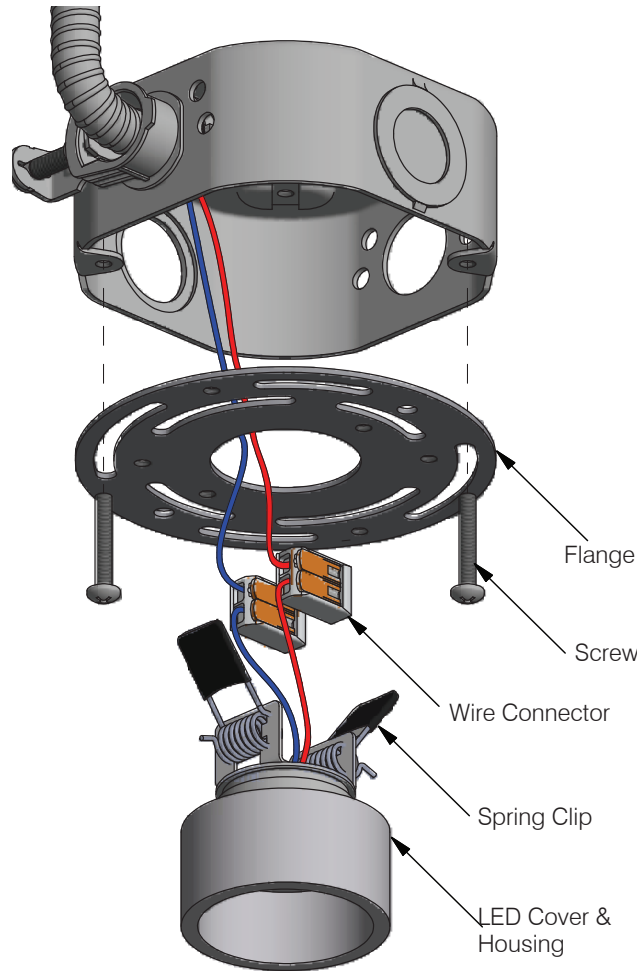

L508-L52

Installation Instructions

⚠ CAUTION

- Read all instructions.
- **WARNING: RISK OF FIRE OR ELECTRICAL SHOCK:** Do not make or alter any openings in the compartment of wiring or electrical components during installation. Do not alter or add ballasts, or any other electrical components.
- Installation and use of this fixture mounting assembly requires a person familiar with the construction and operation of luminaire electrical systems and the hazards involved, if not qualified, do not attempt installation.
- Turn off power before installation.
- Constant current driver only 350mA or 700mA.
- Do not spray water on fixture during cleaning. Avoid using detergents with hand softeners, anti-bacterial agents, glass cleaners or acrylic cleaning products.
- **KEEP THESE INSTALLATION INSTRUCTIONS.**

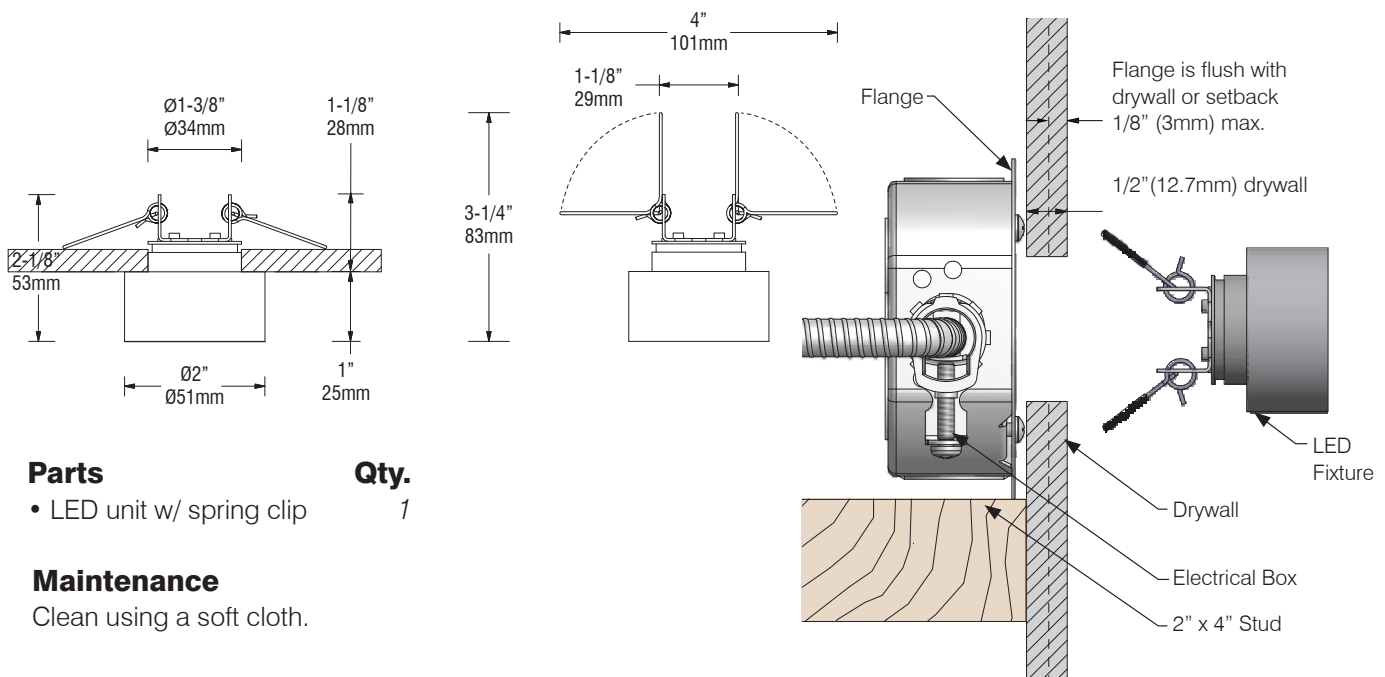

Parts

- LED unit w/ spring clip

Qty.

1

Maintenance

Clean using a soft cloth.



t1.877.708.1184 f604.708.1185 www.mplighting.com
16 West 4th Avenue, Vancouver BC V5Y 1G3, Canada