

L67

Installation Instructions

- 1** Drill a $\text{Ø}1\text{-}1/2"$ ($\text{Ø}38\text{mm}$) hole.
- 2** Connect fixture wires to low voltage wiring (remote LED driver 700mA constant current).
- 3** Push LED housing with friction fit spring clip into $\text{Ø}1\text{-}1/2"$ ($\text{Ø}38\text{mm}$) hole until flush with surface.

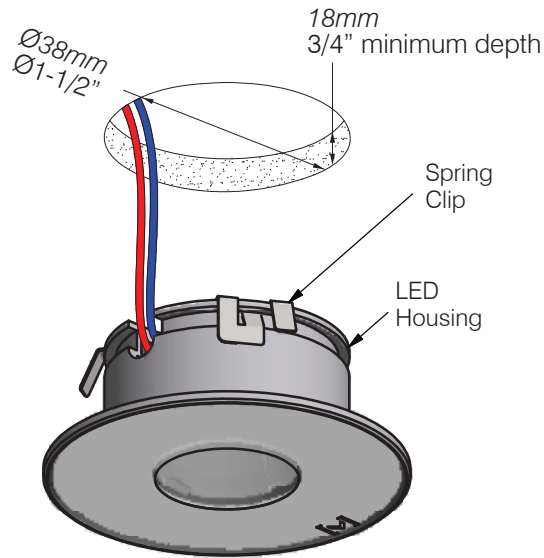

CAUTION

- Read all instructions.
- **WARNING: RISK OF FIRE OR ELECTRICAL SHOCK:** Do not make or alter any openings in the compartment of wiring or electrical components during installation. Do not alter or add ballasts, or any other electrical components.
- Installation and use of this fixture mounting assembly requires a person familiar with the construction and operation of luminaire electrical systems and the hazards involved, if not qualified, do not attempt installation.
- Turn off power before installation.
- 700mA constant current driver only.
- Do not spray water on fixture during cleaning. Avoid using detergents with hand softeners, anti-bacterial agents, glass cleaners or acrylic cleaning products.
- **KEEP THESE INSTALLATION INSTRUCTIONS.**

Parts

- LED unit w/ spring clip

Qty.

1

Maintenance

Clean using a soft cloth.

 **MP LIGHTING**®

t1.877.708.1184 f604.708.1185 www.mplighting.com
16 West 4th Avenue, Vancouver BC V5Y 1G3, Canada

