

L900

Bollard

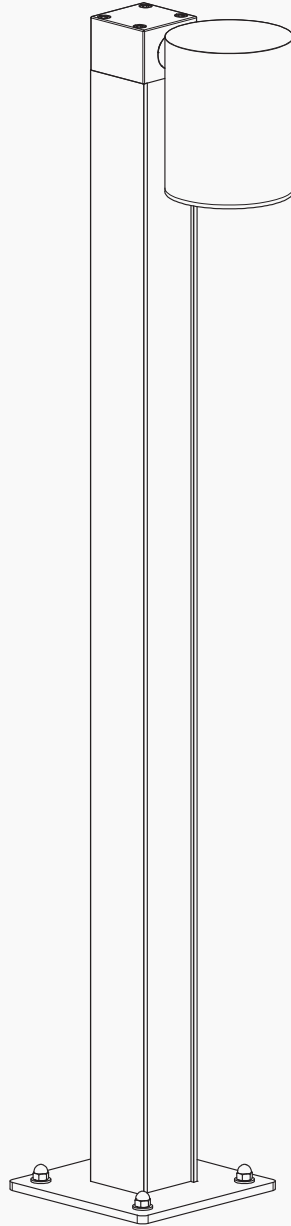

L900

Bollard

Parts

LED unit x 1
Mounting Plate x 1
Base Plate x 1
1/4" Hex bolts x 4
1/4" Hex Cap nuts x 4
RST waterproof connectors x 1
3/4" Flexible conduit (*not included*)
Allen key x 1

- 1) Ensure 1/2" to 3/8" (13 to 10mm) of hex bolt screws should remain above finished concrete when positioning mounting plate.
- 2) Pull 3/4" flexible conduit above Base Plate so it remains above final concrete surface.
- 3) Pull approximately 36" (915mm) of line voltage cabtire cable (*not provided*) so cable remains above final concrete surface.

*Ground wire in cable is necessary.

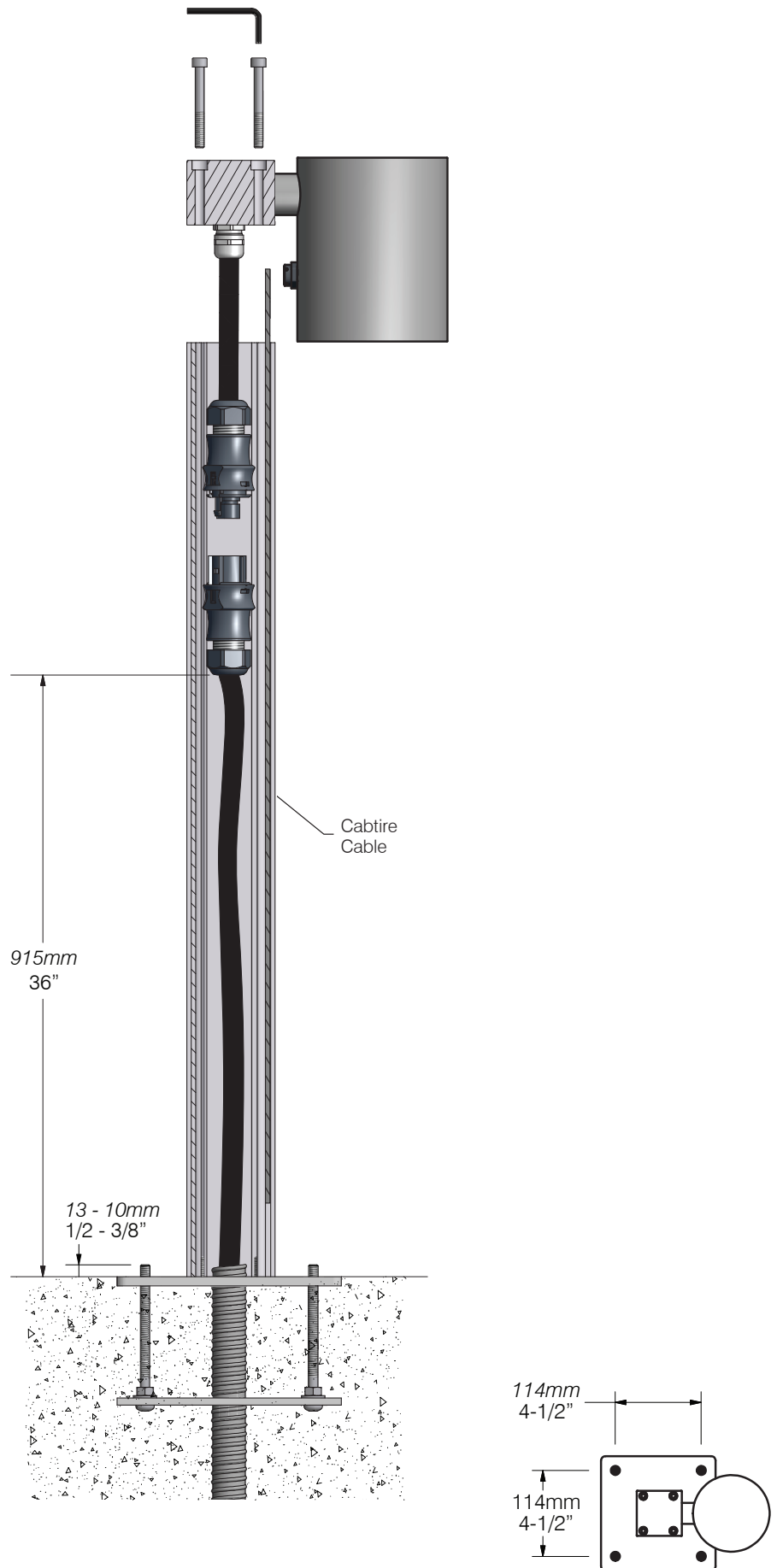

L900

Bollard

Parts

LED unit x 1
Mounting Plate x 1
Base Plate x 1
1/4" Hex bolts x 4
1/4" Hex Cap nuts x 4
RST waterproof connectors x 1
3/4" Flexible conduit (not included)
Allen key x 1

- 1) After mounting plate has been installed (See *Base Positioning*) and concrete has cured, remove protective sleeves from studs.
- 2) Remove front cover plate on fixture.
- 3) Pull cabtire cable through base plate.
- 4) Separate RST waterproof connectors and connect wires.. (See *RST Waterproof Connector Instructions for details*)
- 3) Reconnect both halves of waterproof connector.
- 4) Replace cover plate and mount fixture head by tightening hex screws with Allen key.
- 4) Mount LED Fixture to the base plate using provided countersunk screws (M6).
- 5) Fasten base plate to mounting studs using hex cap nuts.

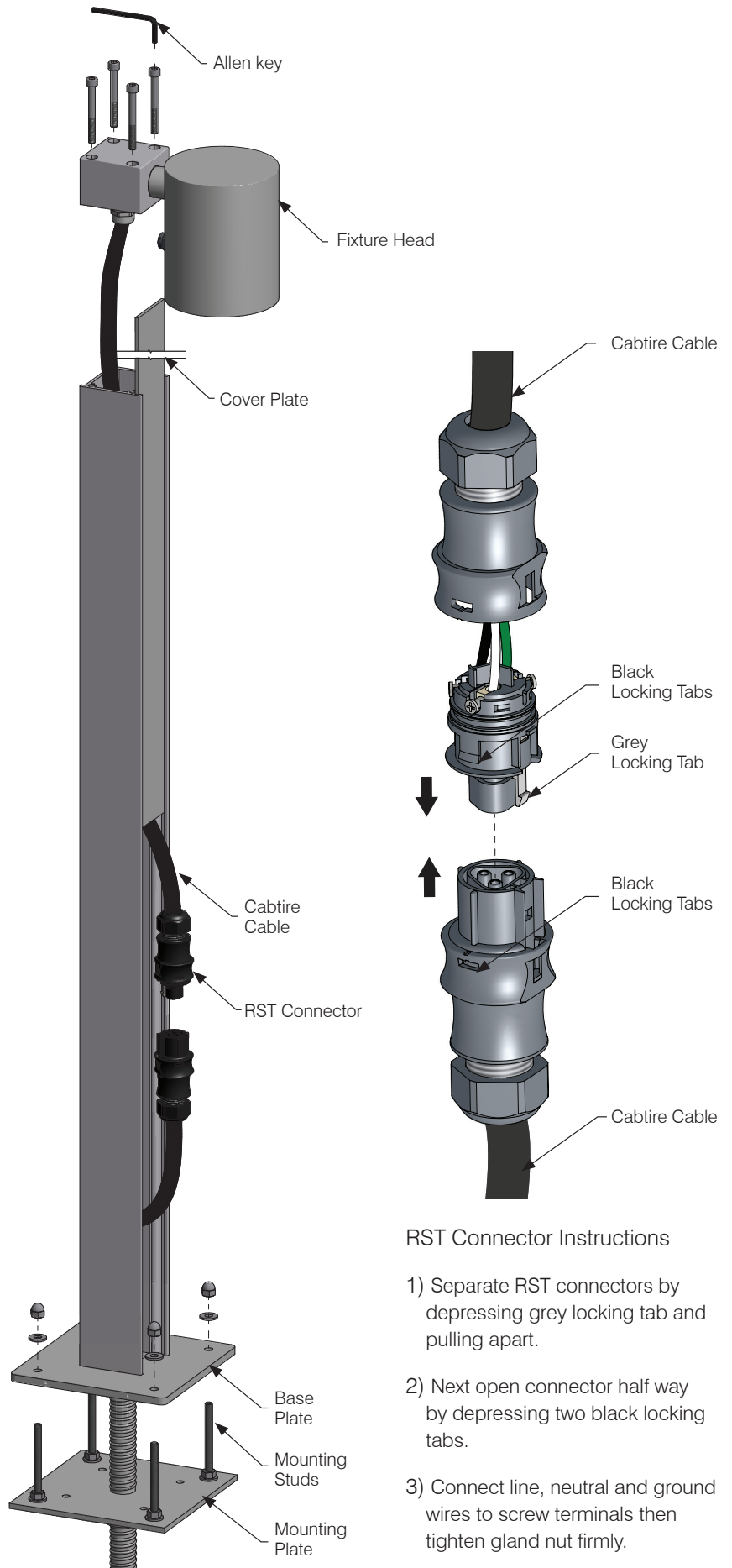

RST Connector Instructions

- 1) Separate RST connectors by depressing grey locking tab and pulling apart.
- 2) Next open connector half way by depressing two black locking tabs.
- 3) Connect line, neutral and ground wires to screw terminals then tighten gland nut firmly.

L900

Bollard

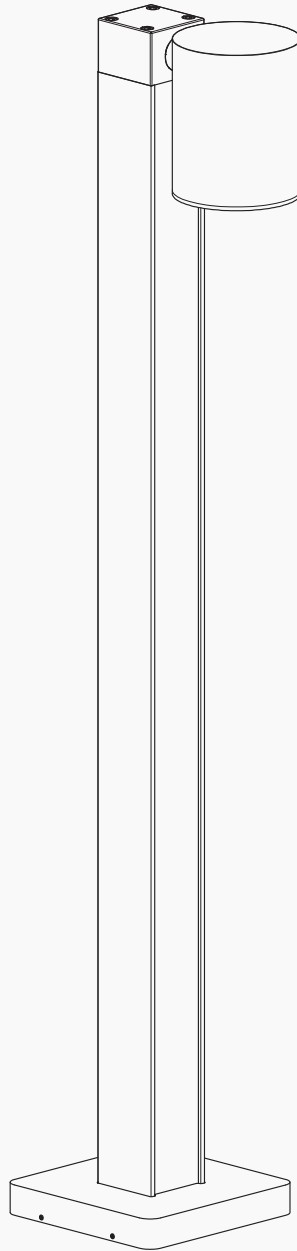

L900

Bollard with Base Cover

Parts

LED unit x 1
Mounting Plate x 1
Base Plate x 1
Base Cover x 1
1/4" Hex bolts x 4
1/4" Hex Cap nuts x 4
RST waterproof connectors x 1
3/4" Flexible conduit (*not included*)
Allen key x 1

- 1) Ensure 1/2" to 3/8" (13 to 10mm) of hex bolt screws should remain above finished concrete when positioning mounting plate.
- 2) Pull 3/4" flexible conduit above Base Plate so it remains above final concrete surface.
- 3) Pull approximately 36" (915mm) of line voltage cabtire cable (*not provided*) so cable remains above final concrete surface.

*Ground wire in cable is necessary.



L900

Bollard with Base Cover

Parts

LED unit x 1
 Mounting Plate x 1
 Base Plate x 1
 Base Cover x 1
 1/4" Hex bolts x 4
 1/4" Hex Cap nuts x 4
 RST waterproof connectors x 1
 3/4" Flexible conduit (not included)
 Allen key x 1

1) After mounting plate has been installed (See Base Positioning) and concrete has cured, remove protective sleeves from studs.

*Ensure base cover is around the LED Fixture before making the wire connections

2) Remove front cover plate on fixture.

3) Pull cabtire cable through base plate.

4) Separate RST waterproof connectors and connect wires.. (See RST Waterproof Connector Instructions for details)

5) Reconnect both halves of waterproof connector.

4) Replace cover plate and mount fixture head by tightening hex screws with Allen key.

5) Mount LED Fixture to the base plate using provided countersunk screws (M6).

5) Fasten base plate to mounting studs using hex cap nuts.

6) Secure base cover to mounting plate by tightening two (M4) set screws on each side.

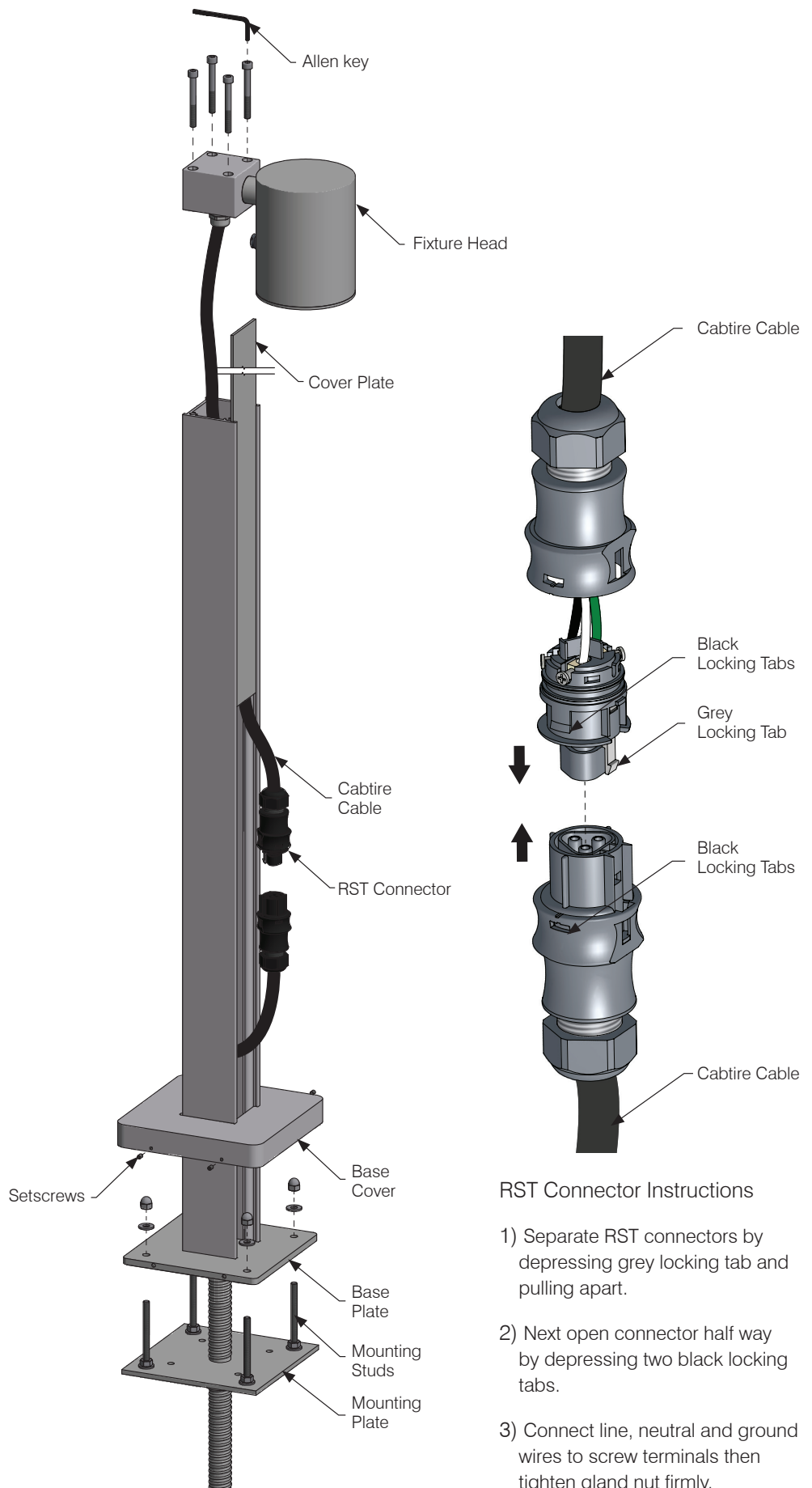

RST Connector Instructions

- 1) Separate RST connectors by depressing grey locking tab and pulling apart.
- 2) Next open connector half way by depressing two black locking tabs.
- 3) Connect line, neutral and ground wires to screw terminals then tighten gland nut firmly.

IMPORTANT SAFETY INSTRUCTIONS

KEEP THESE INSTALLATION INSTRUCTIONS
(Including General and Additional Markings for Fixtures)
(FOR MP LIGHTING LED LUMINAIRES, CLASS 3402-xx)

General and additional markings

1. For Use Only with Certified/NRTL Driver, Model _____
2. DRY LOCATIONS ONLY or OUTDOOR USE ONLY or DRY/
OUTDOOR USE ONLY or Outdoor / submersible Use Only - as
indicated on fixtures
3. MIN 90 C SUPPLY CONDUCTORS
4. Model L92, L900: SUITABLE FOR MOUNTING WITHIN 1.2 M
(4FT) OF THE GROUND
5. Models L01, L03, L05, L06, L07, L08, L300, L302, L304, L306,
L310, L312, L320, L324, L326, L352, L358, L360, L366, L368,
L370, L372, L379: SUITABLE FOR USE IN POURED CONCRETE,
USE ON CLASS 2 CIRCUIT ONLY
6. Models with Class 2 LED Drivers which are intended for
installation for other than Indoor Use Only: CAUTION:
CONNECTED ONLY TO A CIRCUIT PROTECTED BY A CLASS A
GROUND FAULT CIRCUIT INTERRUPTER
7. Models L51, L52, L57, L58, L64, L65, L66, L67, L101, and L102:
SUITABLE FOR UNDER-CABINET MOUNT
8. Model L141, L401NI, L402NI, L403NI, and L405NI: SUITABLE
FOR DAMP LOCATIONS, DO NOT INSTALL INSULATION
WITHIN 76 mm (3 in) OF ANY PART OF THE LUMINAIRE
9. Model L92, L900, L930 (if with remote power supplies): USE ON
CLASS 2 CIRCUIT ONLY
10. Model L122, L123 (if used for recessed applications):
VAPOUR BARRIER MUST BE SUITABLE FOR 90 °C, TYPE IC,
INHERENTLY PROTECTED

Installation instructions

1. The grounding installation shall be done in accordance with
CEC-Part 1.
2. WARNING: RISK OF FIRE OR ELECTRIC SHOCK: DO NOT
MAKE OR ALTER ANY OPENINGS IN THE COMPARTMENT
OF WIRING OR ELECTRICAL COMPONENTS DURING
INSTALLATION. DO NOT ALTER OR ADD BALLASTS, OR ANY
OTHER ELECTRICAL COMPONENTS.
3. INSTALLATION AND USE OF THIS FIXTURE MOUNTING
ASSEMBLY REQUIRES A PERSON FAMILIAR WITH THE
CONSTRUCTION AND OPERATION OF LUMINAIRE
ELECTRICAL SYSTEMS AND THE HAZARD INVOLVED, IF NOT
QUALIFIED, DO NOT ATTEMPT INSTALLATION. CONTACT A
QUALIFIED ELECTRICIAN.
4. TURN OFF POWER BEFORE INSTALLATION.
5. KEEP THESE INSTALLATION INSTRUCTIONS.

CONSIGNES DE SÉCURITÉ IMPORTANTES

CONSERVER CES INSTRUCTIONS D'INSTALLATION
(Dont le général et marques supplémentaires pour les appareils)
(Pour les luminaires LED MP D'ÉCLAIRAGE , CLASS 3402 -xx)

Général et marquages supplémentaires

1. A utiliser uniquement avec Certified / NRTL pilote, modèle _____
2. POUR EMPLACEMENTS SECS SEULEMENT ou UTILISATION
EXTÉRIEURE SEULEMENT ou SEC / UTILISATION EXTÉRIEURE
SEULEMENT ou extérieure / Utilisation submersible seulement -
comme indiqué sur les appareils
3. LES FILS D'ALIMENTATION 90 °C MIN
4. Modèle L92/L900: PEUT ÊTRE INSTALLÉ À MOINS DE 1,2 m (4
pi) DU SOL
5. Modèle L01, L03, L05, L06, L07, L08, L300, L302, L304, L306,
L310, L312, L320, L324, L326, L352, L358, L360, L366, L368,
L370, L372, L379et: PEUT ÊTRE UTILISÉ DANS LE BÉTON
COULÉ, UTILISATION DE CLASSE 2 CIRCUIT UNIQUEMENT
6. ATTENTION: CONNECTED UNIQUEMENT À UN CIRCUIT
PROTÉGÉ PAR UN DISJONCTEUR DIFFÉRENTIEL DE CLASS A
7. Modèle L51, L52, L57, L58, L64, L65, L66, L67, L101, L102 et:
PEUT ÊTRE FIXÉ SOUS UNE ARMOIRE
8. Modèle L141 L401NI, L402NI, L403NI, L405NI: CONVIENT AUX
EMPLACEMENTS HUMIDES, NE PAS METTRE L'ISOLANT À
MOINS DE 76 mm (3 po) DE TOUTE PARTIE DU LUMINAIRE
9. Modèle L92, L900, L930 (avec alimentations à distance):
UTILISATION DE CLASSE 2 CIRCUIT UNIQUEMENT
10. Modèle L122, L123 (pour applications encastrées):LE
PARE-VAPEUR DOIT CONVENIR POUR 90 °C, TYPE IC;
PROTECTION INHÉRENTE

Les instructions d'installation

1. L'installation de mise à la terre doit être fait en conformité avec
CEC Partie 1.
2. AVERTISSEMENT : RISQUE D'INCENDIE OU
D'ÉLECTROCUTION : NE PAS FAIRE OU MODIFIER DES
OUVERTURES DANS LE COMPARTIMENT DE CÂBLAGE OU
DE COMPOSANTS ÉLECTRIQUES LORS DE L'INSTALLATION.
NE PAS MODIFIER OU AJOUTER DES BALLASTS, OU AUTRES
COMPOSANTS ÉLECTRIQUES
3. CE PRODUIT DOIT ÊTRE INSTALLÉ SELON LE CODE
D'INSTALLATION PERTINENT, PAR UNE PERSONNE QUI
CONNAÎT BIEN LE PRODUIT ET SON FONCTIONNEMENT
AINSI QUE LES RISQUES INHÉRENTS. CONSULTER UN
ÉLECTRICIEN QUALIFIÉ.
4. COUPER LE COURANT AVANT L'INSTALLATION.
5. CONSERVEZ CES INSTRUCTIONS.