

LED15W350iZ-01

CONSTANT CURRENT

15W, 350mA, 0-10V dimmable, 120~277V AC Input

○ Damp and Dry location



Ordering Information Clear Form

Date : _____ Project : _____ Type : _____	Quantity : _____ Note : _____
---	----------------------------------

Specifications

LED Driver | Example Code: LED15W350iZ-01-B

Product	Enclosure
LED15W350iZ-01	B
	B driver enclosure

Important Notes

Warranty Notes & Disclaimer

MP Lighting reserves the right, at its sole discretion, at any time and without notice, to make improvements and innovations to any of our products. Consult MP Lighting website for further details.

1. Do not install on-off switch at the output (load) side of a constant current LED driver as it will damage the fixture(s) and will void the warranty on both driver and fixture(s).
2. Fixtures must be wired as per MP Lighting's instruction (series wiring for constant current driver and parallel wiring for constant voltage drivers.) Failures due to improper installation will void warranty.

Dimensions

Driver

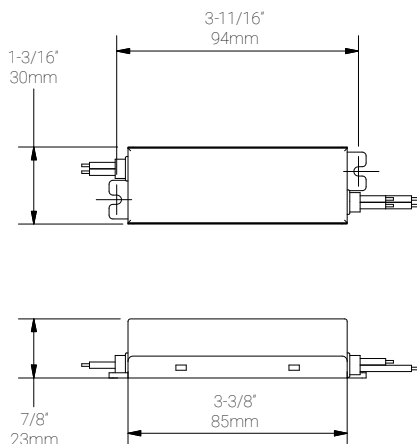

Driver with Enclosure (EBX-160-ZP)

